



GR1 SERIES SINGLE-CHAMBER FILM GRINDERS

AEC's GR1 Series film grinders are designed to handle a wide range of materials and can be equipped with our exclusive feed roll assemblies for automatic feeding of scrap roll stock. GR1 Series film grinders are used to grind film scrap into small particles of fluff that can be combined with pelletized material and fed back into an extruder.



Model GR1-812-20

STANDARD FEATURES

- Frame-mounted control panel complete with all starters, relays, switches, etc. required for proper operation
- Frame-mounted fluff blower
- Heavy-machined plate cutting chamber
- Outboard-mounted bearings with scraper blades
- High shear, scissor cut design
- 4-blade adjustable slant knife rotor, 1 bed knife; D2 steel
- Reinforced grinder screen
- 460/3/60 supply voltage

OPTIONAL FEED ROLL ASSEMBLY FEATURES

- Doctor blade on lower roll to help reduce wrapping
- Exclusive "undercut" knurl design helps prevent knurl wear
- Heavy-duty hollow shaft gearbox and variable speed drive motor
- Front door with hinge and quick-release clamp
- Adjustable finger guards
- Assembly hinged with quick-release clamp for cleaning
- Pneumatic assist provided with Model 20 & Model 30 assemblies
- Angled feed roll geometry to assist in feeding thick films
- Steep wall grinder chute to advance roll stock and film
- Optional feed roll reversing switch available
- Safety switches on all hinged components

OPTIONAL FEATURES

- Special voltage (specify)
- Standard hand feed chute
- Flywheel on grinder for heavy feeding
- Sound enclosure
- Carbide-coated grinder blades in lieu of D2 (5 blades)
- CPM10V grinder blades in lieu of D2 (5 blades)
- Additional spare set of D2 blades
- Feed roll reversing switch
- Remote-mount control panel
- Soft start; minimum 50 HP (37 kW) drives

GR1 SERIES FILM GRINDERS

BLEND AND RECLAIM

SPECIFICATIONS

Model	Grinder motor, HP (kW)	Fluff blower motor, HP (kW)	Grinder rate range, lbs./hr (kg/hr) ¹	Screen hole dia., in. (mm) ²
GR1-8012-20	20 (14.92)	2 (1.49)	225-275 (102-124)	0.1875 (4.762)
GR1-1218-30	30 (22.38)	5 (3.73)	350-450 (159-204)	0.1875 (4.762)
GR1-1218-40	40 (29.84)	5 (3.73)	400-500 (181-227)	0.1875 (4.762)
GR1-1824-75	75 (55.95)	10 (7.46)	600-1000 (272-454)	0.3125 (7.438)

1 Feed rate range is based on 1.0 mil LDPE film scrap; actual rate will vary. Material types and thickness can greatly impact the performance of film grinders. AEC is not responsible for grinder performance under certain operating conditions with which the equipment is not designed to handle, or if the material type and thickness is not known or specified with the order. It is the responsibility of the salesperson and the customer to inform the factory of the exact scrap film application with confirming orders.

2 Screen hole diameter in mm is approximate. Screen size required may vary depending on the material type and thickness.

FEED ROLL ASSEMBLIES

Description	Models
Model 14 with 1/2 HP (0.373 kW) SCR drive (up to 60" layflat)	Model 812 only
Model 14 with 3/4 HP (0.559 kW) SCR drive (up to 84" layflat)	Models 812 and 1218
Model 20 with 1.5 HP (1.12 kW) SCR drive (up to 120" layflat)	Models 1218 and 1824
Model 30 with 5 HP (3.73 kW) SCR drive (up to 160" layflat)	Model 1824 only

DIMENSIONS

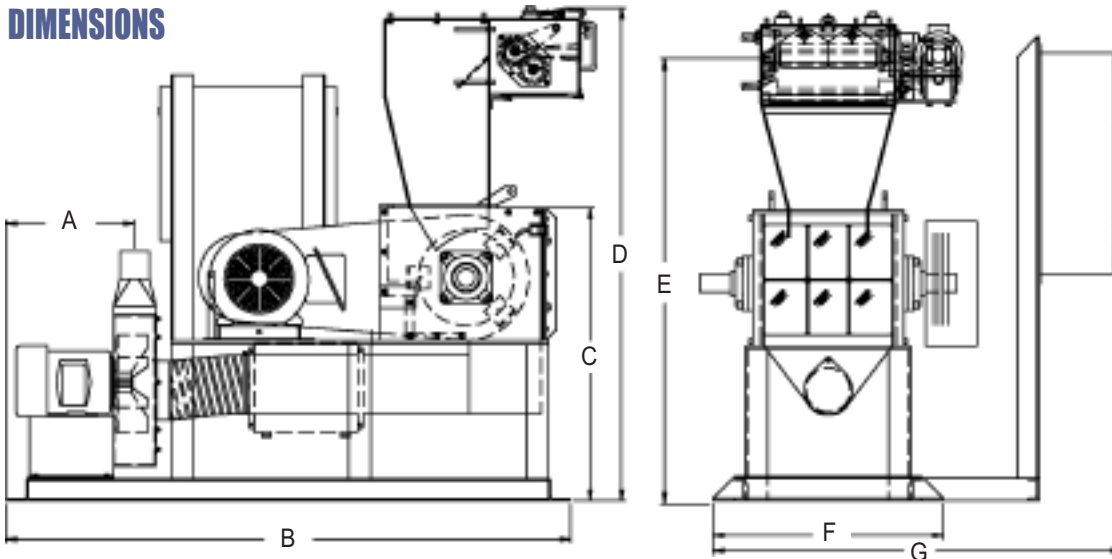

Shown with optional feed roll assembly

Model	A, in. (cm)	B, in. (cm)	C, in. (cm)	D, in. (cm)	E, in. (cm)	F, in. (cm)	G, in. (cm)
812	20 (51)	69 (176)	33 (83)	45 (113)	60 (151)	24 (61)	51 (129)
1218	17.5 (45)	77 (196)	40 (102)	67 (171)	61 (155)	32 (80)	56 (145)
1824	Consult factory						